

La communication interne, facteur de réussite d'un projet ... européen

Danièle IMBAULT, CEA Saclay

Projet : pilotage et négociation

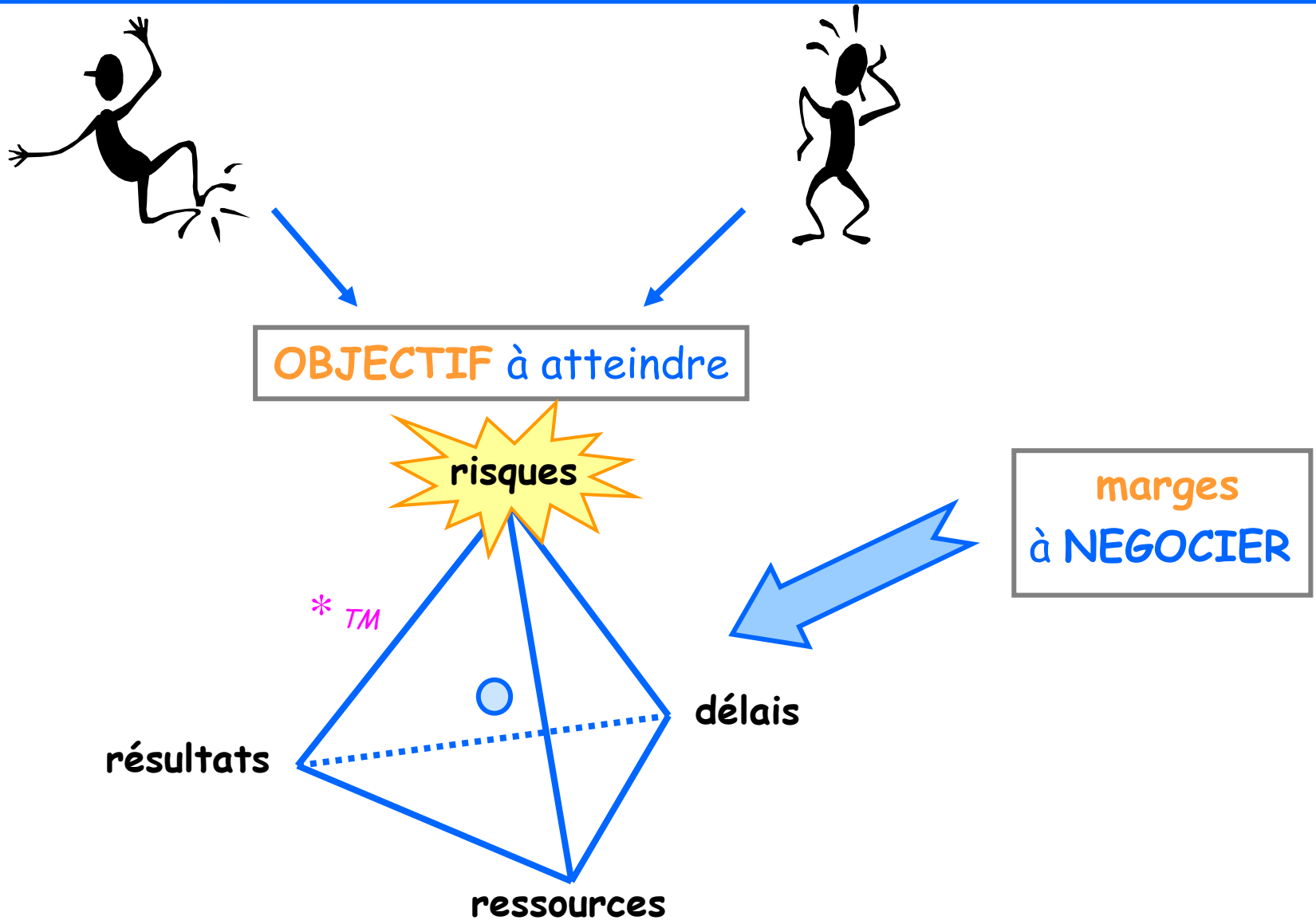

* Berlingot - marque déposée par le CEA

conduire un projet = piloter la COHERENCE

Mobiliser par la gestion des risques

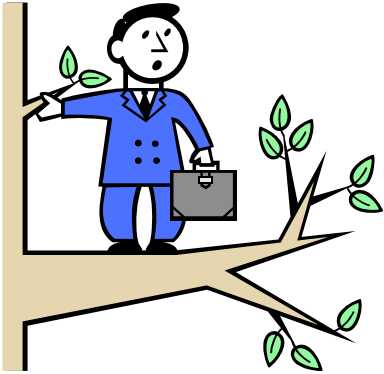

L'imprévu n'est pas forcément imprévisible mais il est souvent le fait d'une réflexion initiale insuffisante...

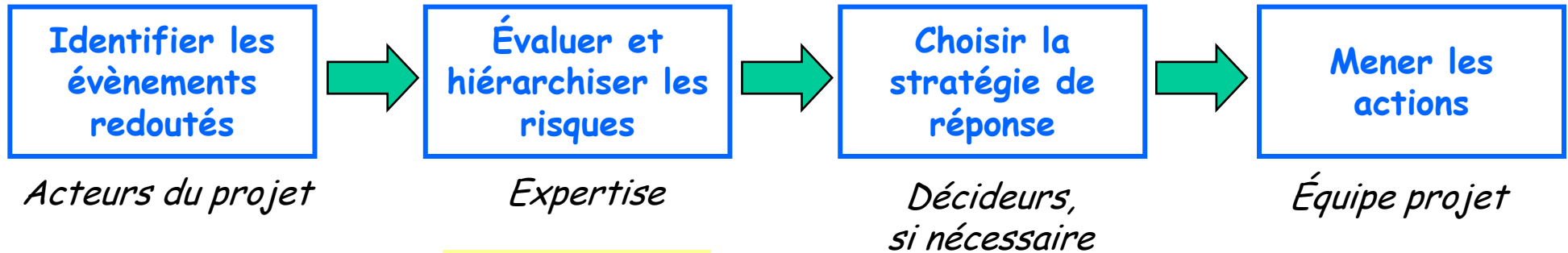

gravité

$$C = P \times G$$

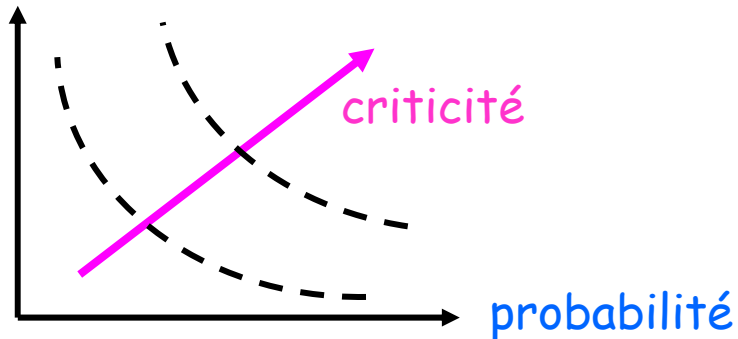

*Le gagnant sait ce qu'il fera s'il perd...
Le perdant ne pense souvent qu'à ce qu'il fera s'il gagne...*

La stratégie de traitement des risques

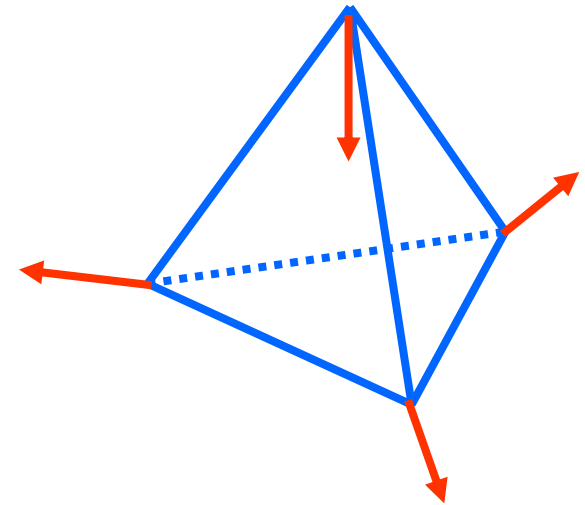
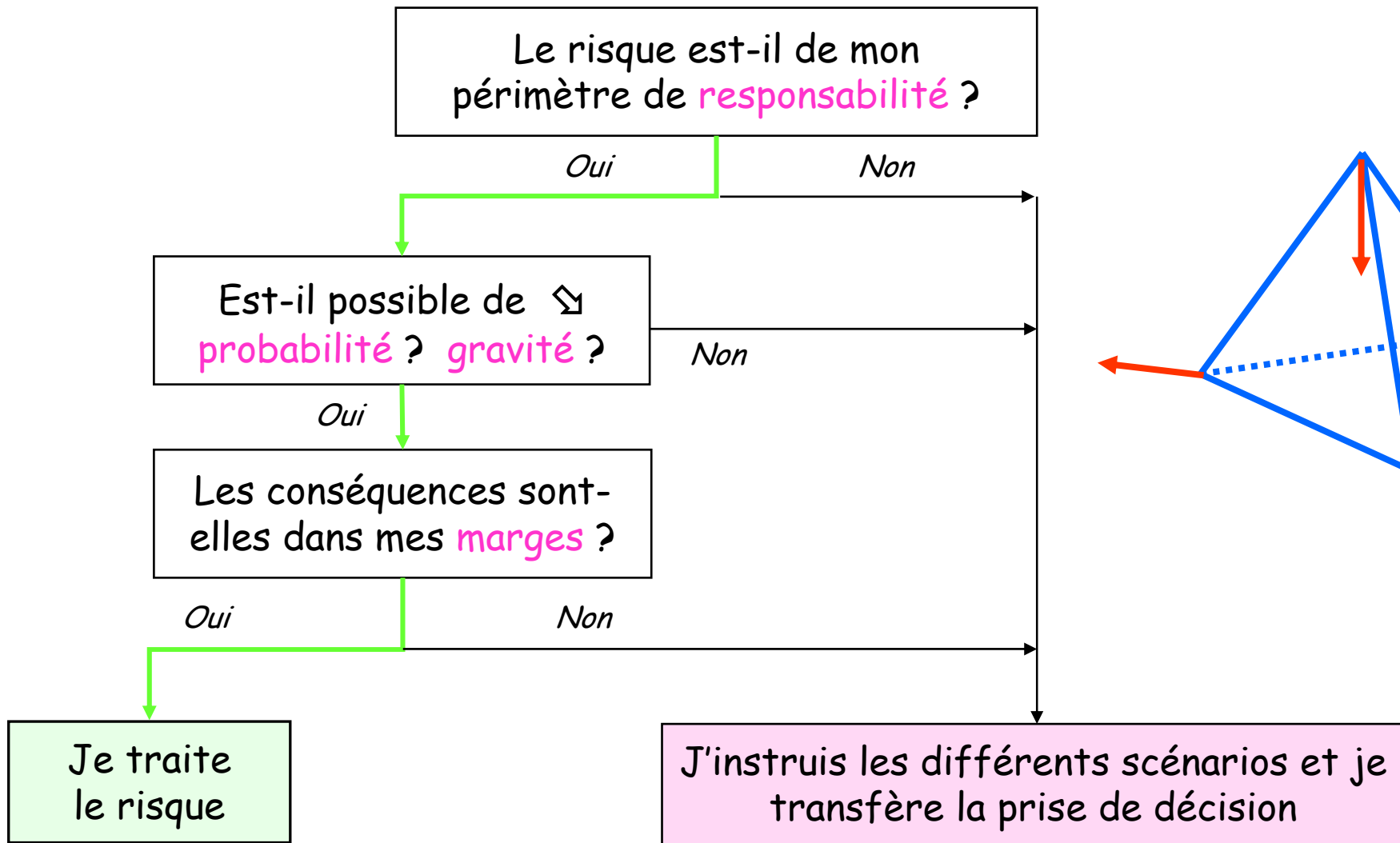

A chacun son berlingot...

OTP, WBS...

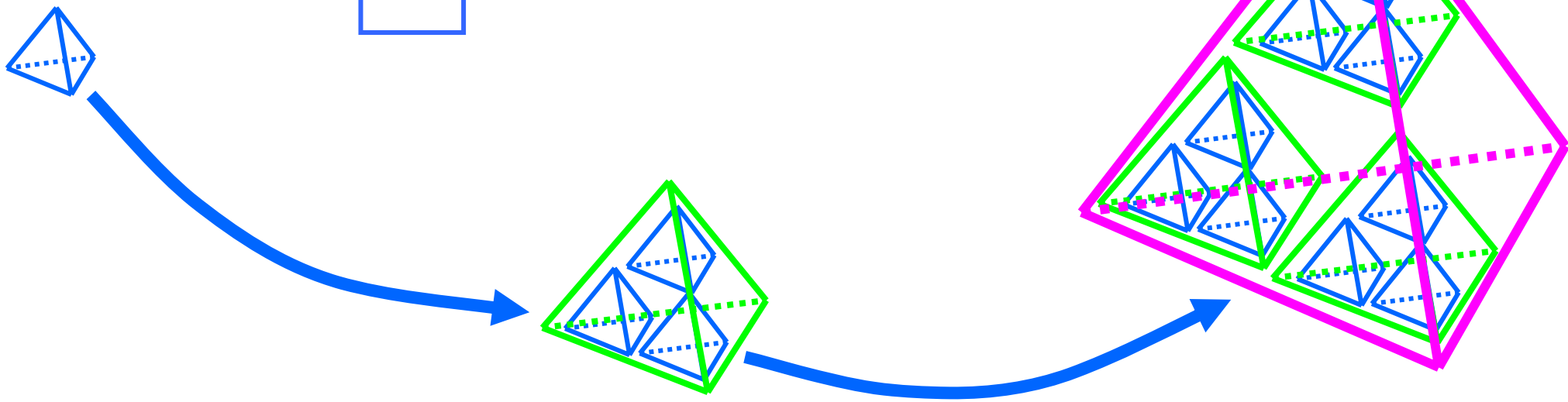
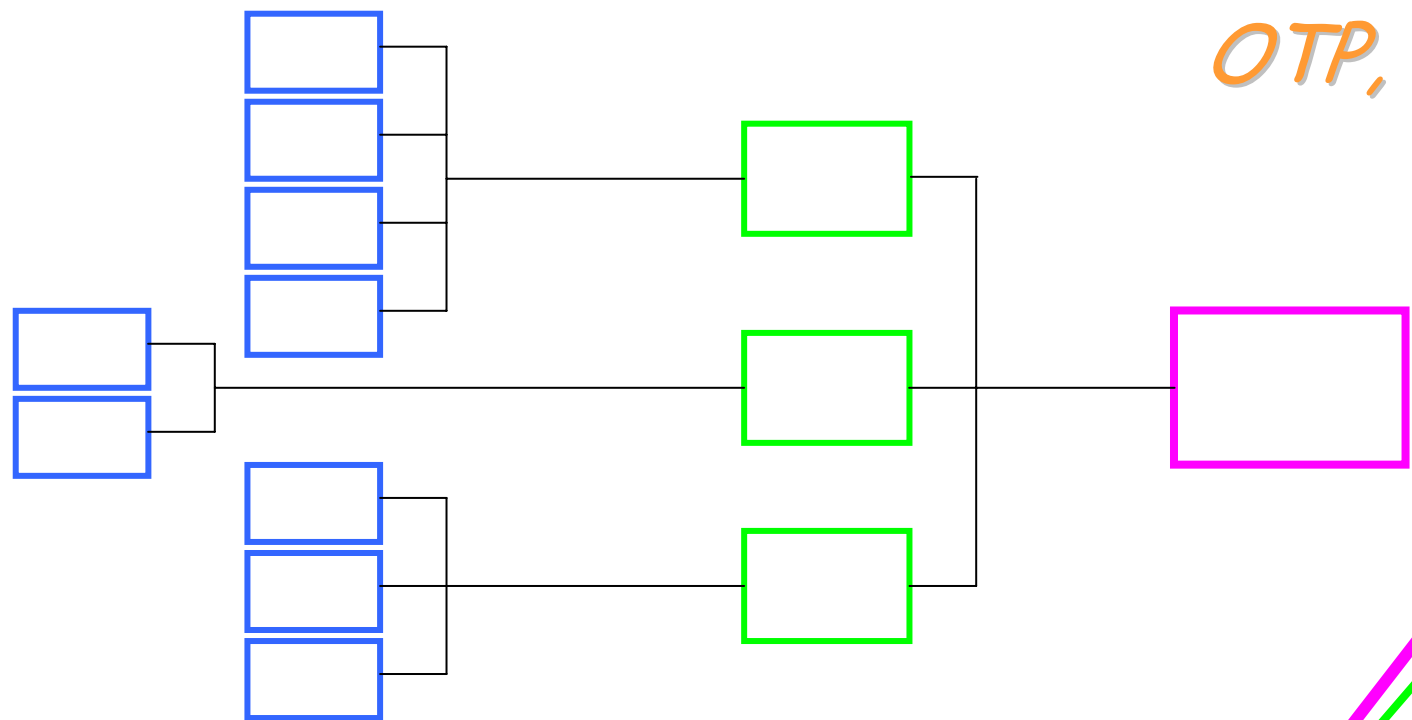

Organisation matricielle et processus de décision

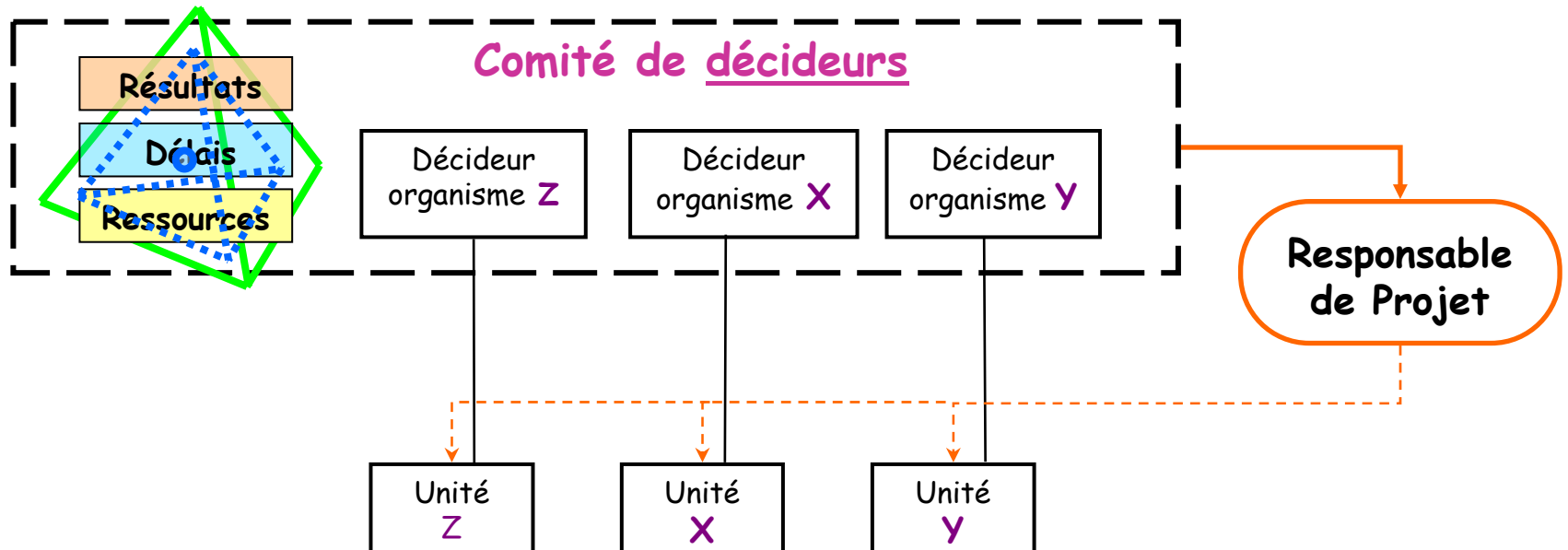
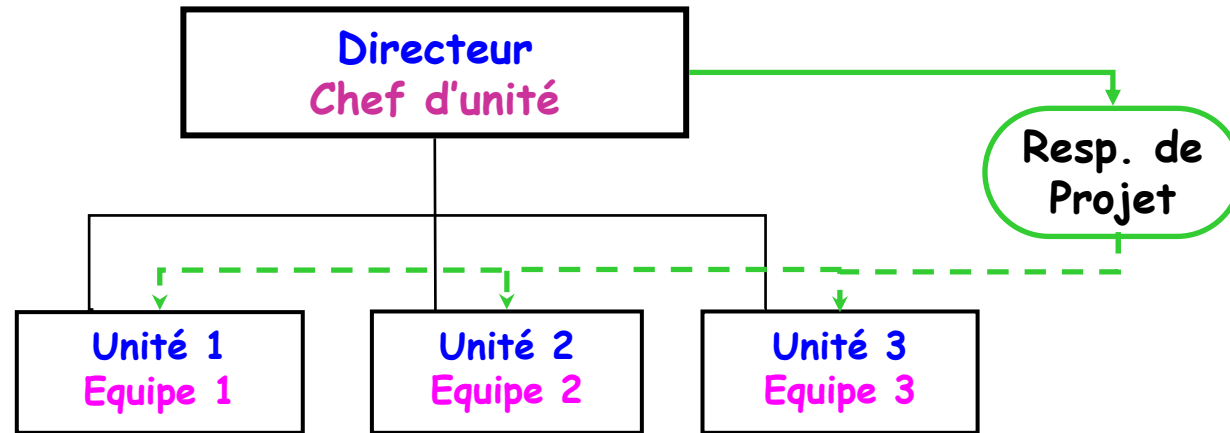

Le phasage et les revues de projet

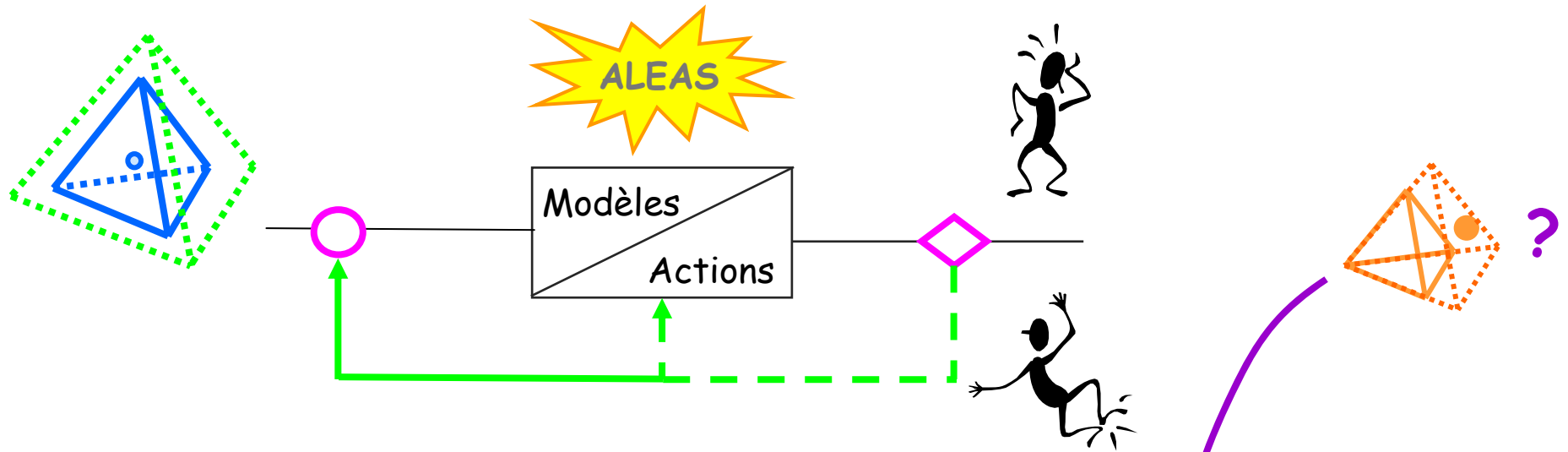

COHERENCE
→ confiance

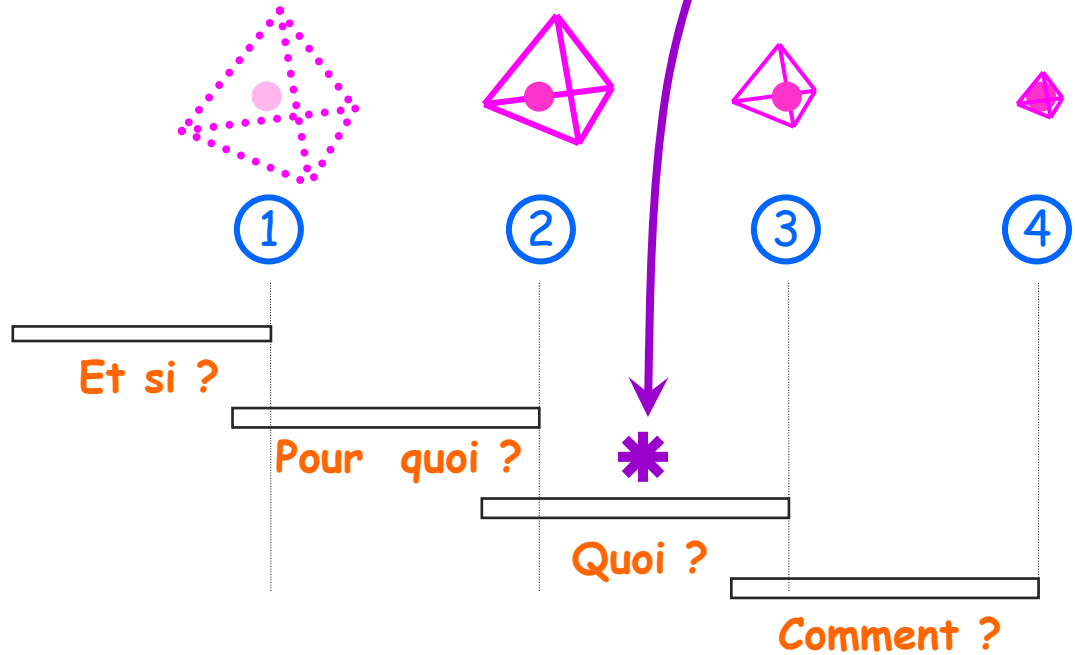
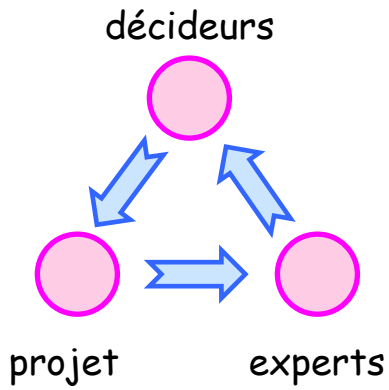

Déroulement et coordination du projet

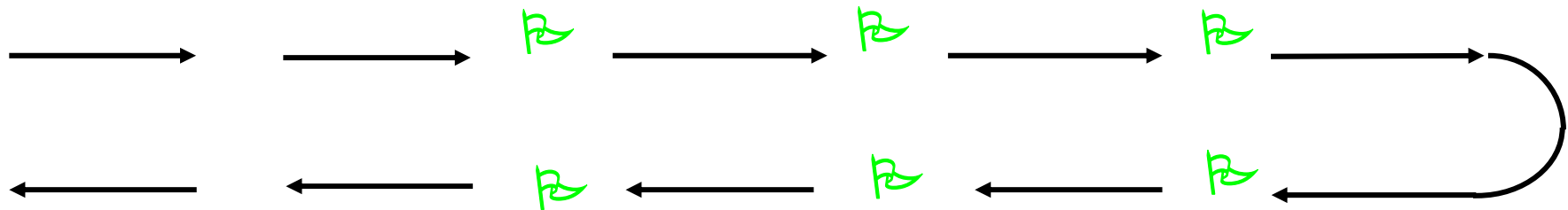
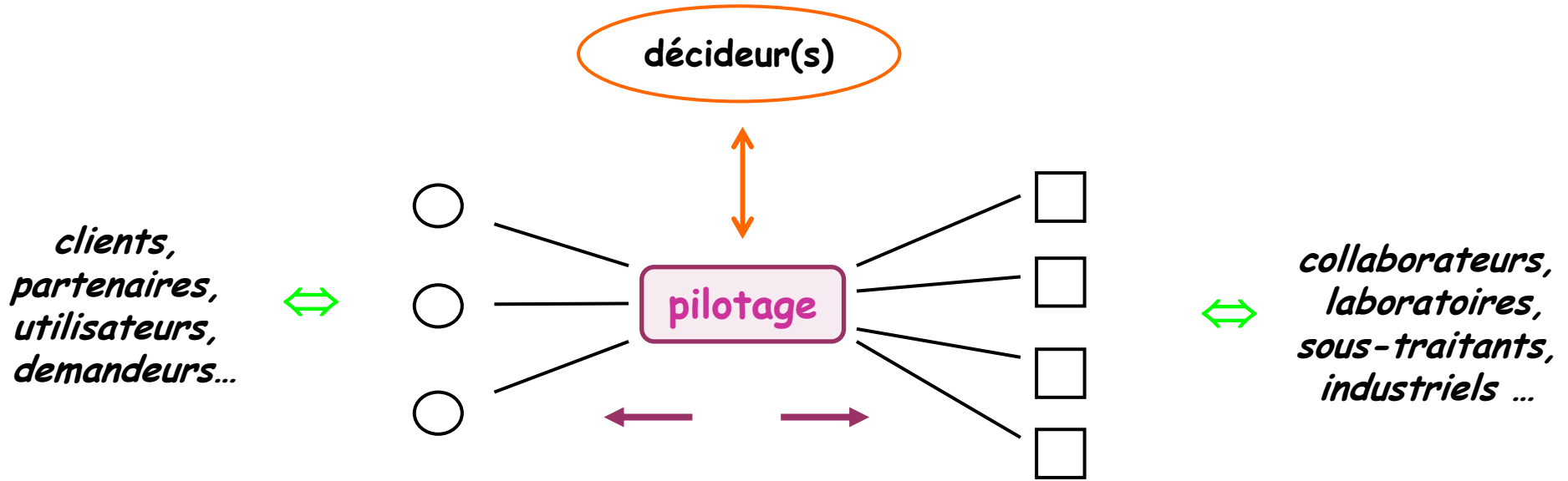

Coordinateur = responsable scientifique + chef de projet ?

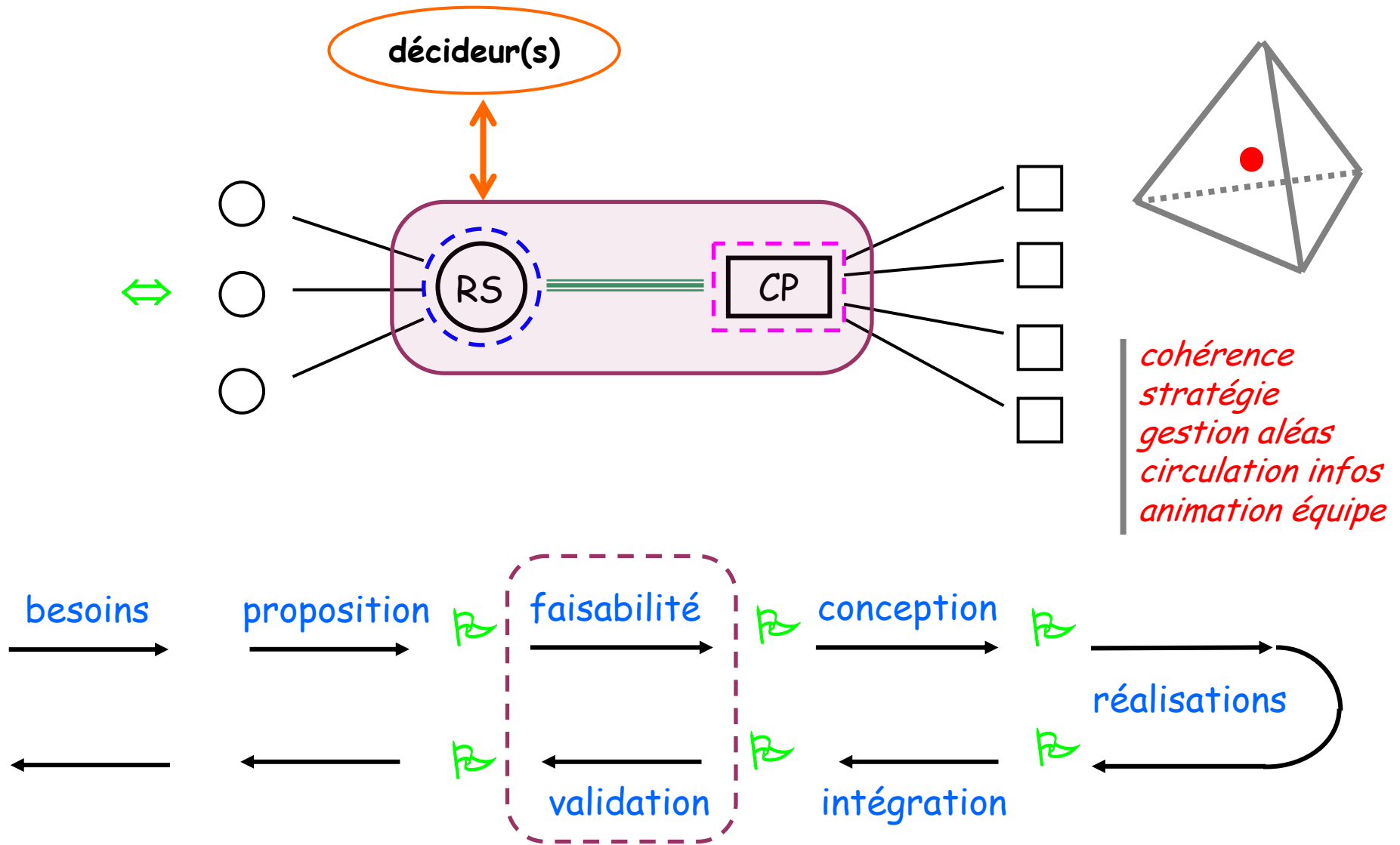

Animer/piloter un projet, c'est donc ...

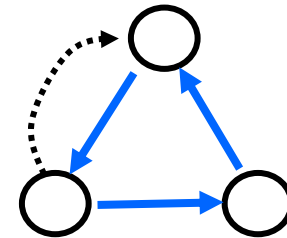
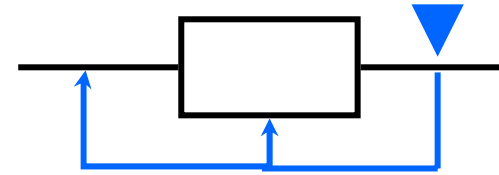
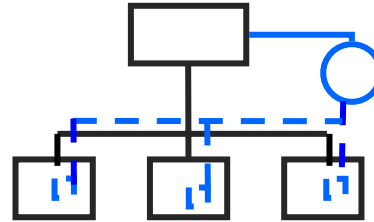
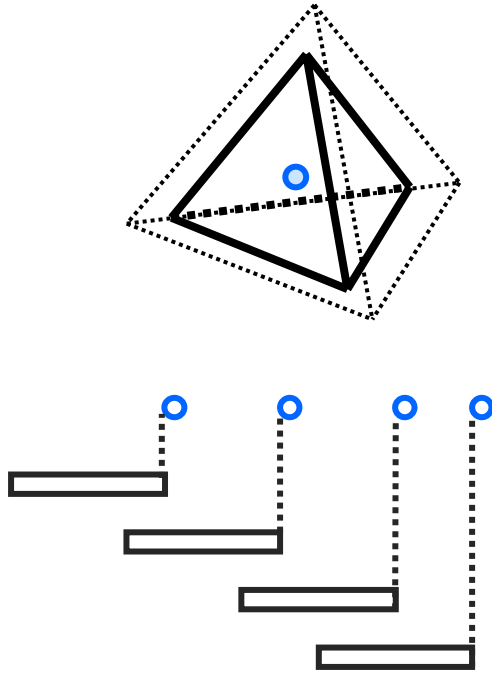

... mais une méthodologie ou des outils ne sont efficaces que si les acteurs sont mobilisés pour les mettre en œuvre ...



"petit" projet
+ technique



"grand" projet
+ relationnel

Quelles compétences pour le responsable du projet ?

rigueur

*observation
écoute*

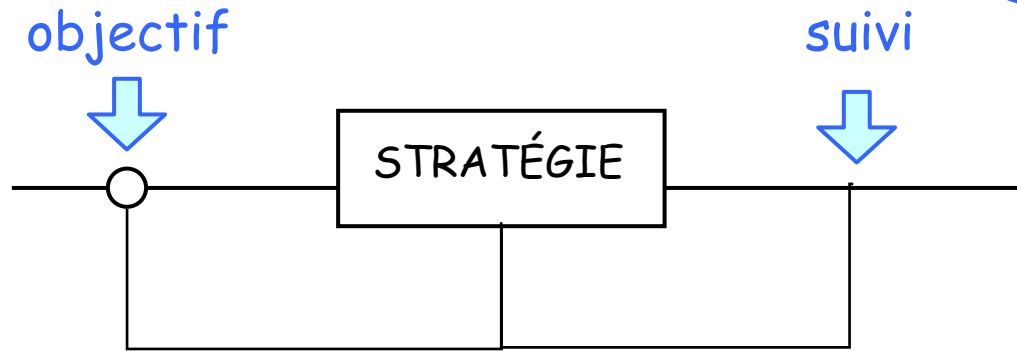

flexibilité

tactique

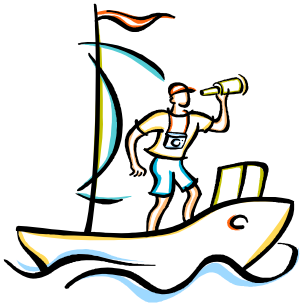

*Chef d'orchestre
&
Navigateur*



"Le talent, c'est d'en trouver aux autres"
(Robert Hossein)

Complexité, communication interpersonnelle et motivation

